

M-N XN- RK

Multijet Inferential Domestic water meter
with built-in reed pulser
40 °C / PN 16



Special Features

The Sensus multi-purpose meter with a built in reed pulser is ideal for use with:

- Remote reading systems
- Central billing systems
- Dosing pump systems
- Data logging systems eg. CDL Data Logger

Reed pulser

- Specially selected reliable and durable reed switch with a stress relieved connection cable
- Reed pulser can be replaced without breaking the verification seal and without shutting off the water flow
- Easily readable register even with the reed pulser fitted



M-N XN-RK
for horizontal installation



M-N XN-RK
for vertical pipe installation

www.sensus.com
info.int@sensus.com

 **SENSUS**
METERING SYSTEMS

Performance Table

Nominal size	Q_n	m ³ /h	2.5	6	10
Maximum flow rate	Q_{max}	m ³ /h	5	12	20
Headloss at Q_{max}		bar	0.51	0.85	0.75
Flowrate at 1 bar head loss		m ³ /h	7	13	23
Transitional flowrate	Q_t	l/h	120	280	600
Minimum flowrate	Q_{min}	l/h	20	25	30
Maximum loading			Dependent on head loss characteristics		

Accuracy limits For flowrates between Q_t and $Q_{max} \pm 2\%$
For flow rates below Q_t to $Q_{min} \pm 3\%$

The Q_t and Q_{min} values shown are Sensus performance data, which substantially exceed the legal requirements.

Technical Specifications of the Reed Switch

Switch type: Reed switch (magnetic switch in inert gas)	
ASA switch type	A
Protection class	IP 65
Switch material	Rh
Max. switch load in W/VA	0.2
Max. switching current in A (peak value)	0.1
Max. voltage in Vs	48 V DC *
Max. resistance in mOhm	150
Min. electric strength (1 sec.) in Vs	250 *
Rising excitation in AW	10 ... 30
Falling excitation in AW	8 ... 28

Note:

When switching inductive loads, switch protection must be used (diodes or other)

When switching electronic systems, PLC's etc, suitable bounce suppression or pulse filtering may be required

Check the manufacturers requirements

* voltages above 48V are not permitted!

Pulse Values

Pulse value l/pulse								
Q_n 2,5			Q_n 6			Q_n 10		
0.25	1	0,5	1			1		
2.5	10	5	2.5	10	5	.,5	10	5
25	100	50	25	100	50	25	100	50
250	1000	500	250	1000	500	250	1000	500

Pulse values of 0.25 / 0.5 / 1 Litre are not suitable for verification

Materials

All parts of the measuring insert are made of high quality plastics. They are extremely corrosion and dirt resistant. Special plastics are also used for bearings.

- Measuring element: Plastic
- Roller counter shaft and roller drive shaft: CrNi Steel
- Body: Brass
- Head ring: Forged brass
- O-rings: Rubber
- Sliding ring: Erolon
- Dial glass: Plastic

Typical Accuracy Curve

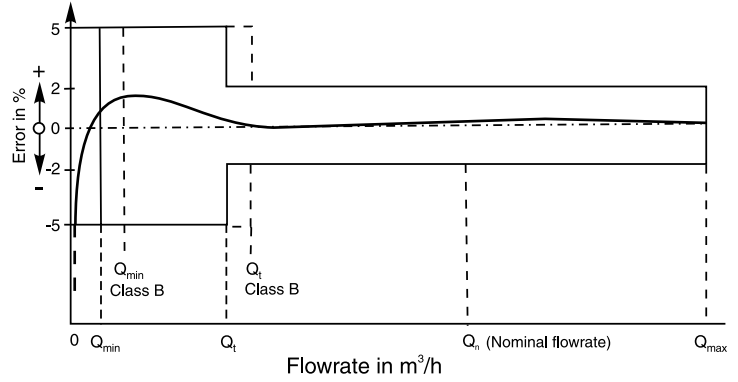

Dial Face

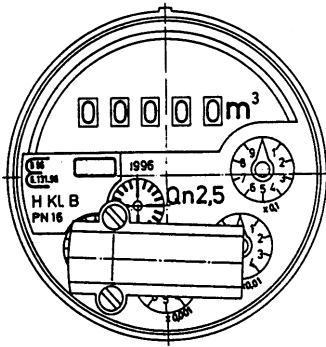

Typical Head Loss Curve

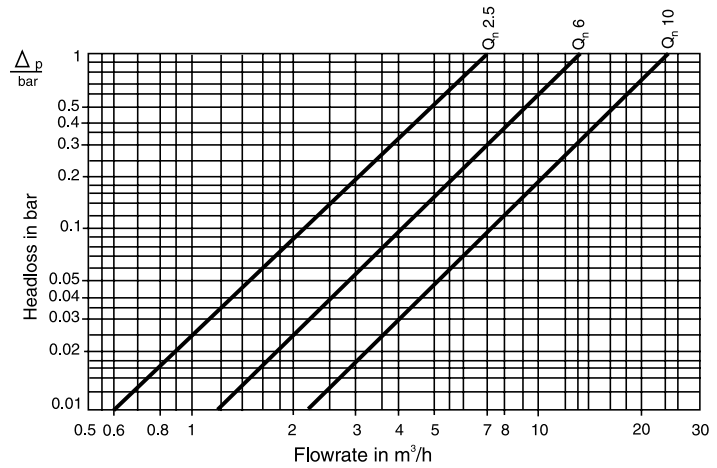

Dimension Picture

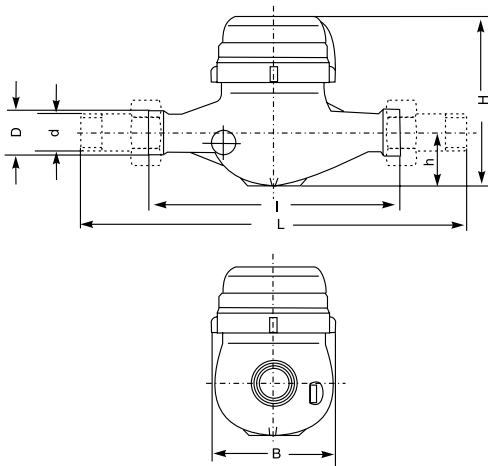

Dimensions and Weights

Horizontal version		Q _n	2.5	6	10
Connection size	inch		3/4	1	1 1/2
Tailpiece connection thread	d inch		R 3/4	R 1	R 1 1/2
Meter connection thread	D inch		G 1 B	G 1 1/4 B	G 2 B
Length					
without tailpieces	l mm		190	260	300
with tailpieces	L mm		288	378	438
Height	h mm		36	46	62
Height	H mm		127	147	175
Width	B mm		95	103	131
Weight					
without tailpieces	kg		1.6	2.7	5.4
with tailpieces	kg		2	3.3	6.6

M-N XN-RK

Ordering Information

Litre / pulse	Nominal size Q _n 2,5	Nominal size Q _n 6	Nominal size Q _n 10
0,25	MN Q _n 2,5 XN RK 0,25	Not suitable for verification or pattern approval	
0,5	MN Q _n 2,5 XN RK 0,5		
1	MN Q _n 2,5 XN RK 1		
10	MN Q _n 2,5 XN.EBH.RK 10	MN Q _n 6 XN.EBH.RK 10	MN Q _n 10 XN.EBH.RK 10
100	MN Q _n 2,5 XN.EBH.RK 100	MN Q _n 6 XN.EBH.RK 100	MN Q _n 10 XN.EBH.RK 100
1000	MN Q _n 2,5 XN.EBH.RK 1000	MN Q _n 6 XN.EBH.RK 1000	MN Q _n 10 XN.EBH.RK 1000
2,5	MN Q _n 2,5 XN.EB. RK 2,5	MN Q _n 6 XN.EB. RK 2,5	MN Q _n 10 XN.EB. RK 2,5
5	MN Q _n 2,5 XN.EB. RK 5	MN Q _n 6 XN.EB. RK 5	MN Q _n 10 XN.EB. RK 5
25	MN Q _n 2,5 XN.EB. RK 25	MN Q _n 6 XN.EB. RK 25	MN Q _n 10 XN.EB. RK 25
50	MN Q _n 2,5 XN.EB. RK 50	MN Q _n 6 XN.EB. RK 50	MN Q _n 10 XN.EB. RK 50
250	MN Q _n 2,5 XN.EB. RK 250	MN Q _n 6 XN.EB. RK 250	MN Q _n 10 XN.EB. RK 250
500	MN Q _n 2,5 XN.EB. RK 500	MN Q _n 6 XN.EB. RK 500	MN Q _n 10 XN.EB. RK 500