



### Special Features

---

#### MAG 3100W

High measuring accuracy ( $\pm 0.5\%$  of measured value)  
Earthing electrodes integrated in the measuring tube  
Simple commissioning by SENSORPROM

#### MAG 3100

High measuring accuracy ( $\pm 0.25\%$  of measured value together with MAG 6000)  
Various selection of liner and electrode materials  
Further features please see MAG 3100W

#### MAG 5000

High measuring accuracy ( $\pm 0.5\%$  of measured value)  
Wide measuring range  
Simple commissioning by SENSORPROM  
No calibration necessary  
Self diagnosis  
LCD-indicator, Current output, Pulse output  
Empty pipe detection  
Flow-direction signal  
Converter for compact/remote mounting  
Automatic zero point adjustment

#### MAG 6000

High measuring accuracy ( $\pm 0.25\%$  of measured value; together with MAG 3100W  $\pm 0.5\%$ )  
Batch function  
Limit switch  
MAG 6000 CT with pattern approval for cold water  
Further features see MAG 5000



Converter  
MAG 5000 / MAG 6000

Sensor  
MAG 3100W

## Models available

### Sensor MAG 3100W

DN 25 ...	DN 1200	70 °C
DN 25 ...	DN 50	PN 40
DN 65 ...	DN 150	PN 16
DN 200 ...	DN 1200	PN 10

Liner: Neoprene (Standard)  
EPDM (with KTW-approval)

Electrodes: AISI 316 Ti

Pipe connections: Flanges acc. to DIN 2501

Earthing electrodes: Stainless steel

Converter MAG 5000 115/230 V AC

Converter MAG 5000 24 V AC/DC

Converter MAG 6000 115/230 V AC

Converter MAG 6000 24 V AC/DC

Converter MAG 6000 CT 115/230 V AC

- Other models on request

## Pattern Approval Sign

6.221	for MAG 6000 CT
99.19	30 °C

## Applications

Measurement of water up to 70 °C

Measurement of waste water

Process control

District metering

Measurement of aggressive mediums and liquids with different viscosities

Batching of fluids (MAG 6000)

## Installation Requirements

Upstream unrestricted straight pipe min. 5 x DN

Downstream unrestricted straight pipe min. 2 x DN

May be installed at any angle

Pipe must always be filled with liquid.

## Measuring Range

The table (see right) shows the relationship between flow velocity  $V$ , flow quantity  $Q$  and sensor dimension DN.

### Selecting of sensor

Normally, the sensor is chosen so that at full scale velocity  $V$  is 2 ... 3 m/s or more.

For measuring of mediums with high solids content  $V$  should be 3 ... 5 m/s to avoid deposition

### Prerequisites

Medium pumpable with a conductivity of min 5 $\mu$ S/cm.

Power supply 115/230 V AC or 24 V AC/DC.

## Sizing Table (DN 25 ... DN 1200)

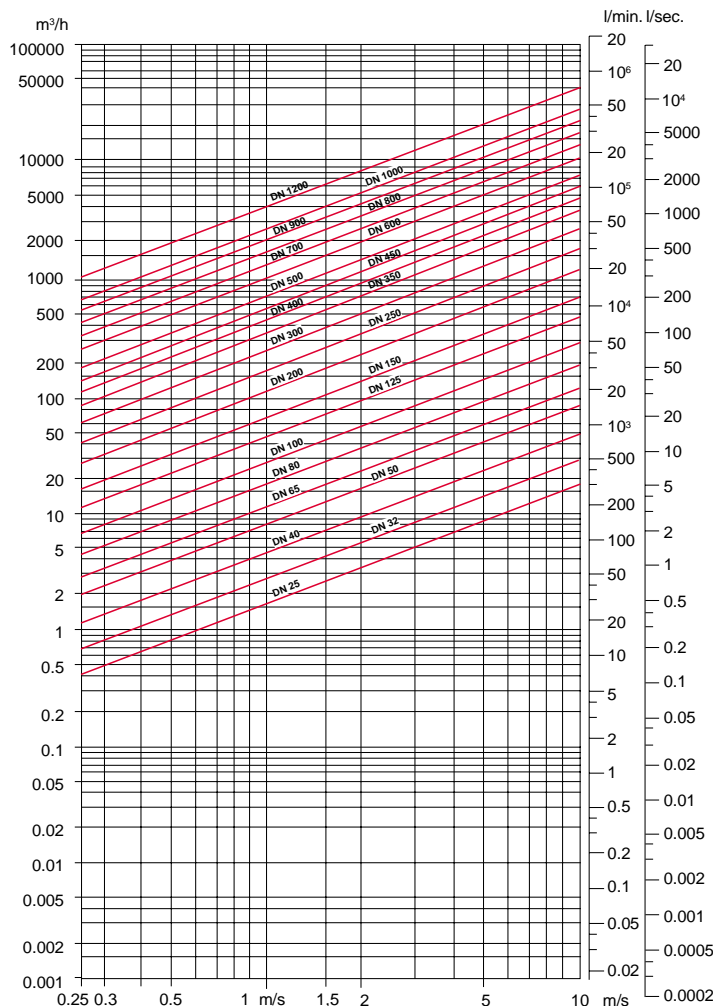

# Measuring Deviation

# Dimension Pictures

under reference conditions

(Display, Frequency, Pulse output)

MAG 3100W/5000 · MAG 3100W/6000

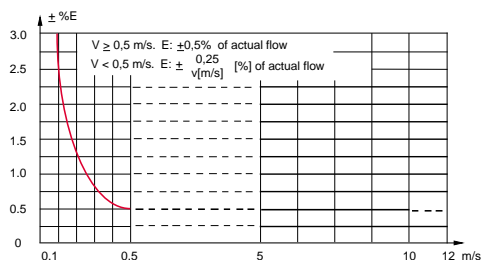

V: actual flow velocity (m/s), E: Error in % of actual flow

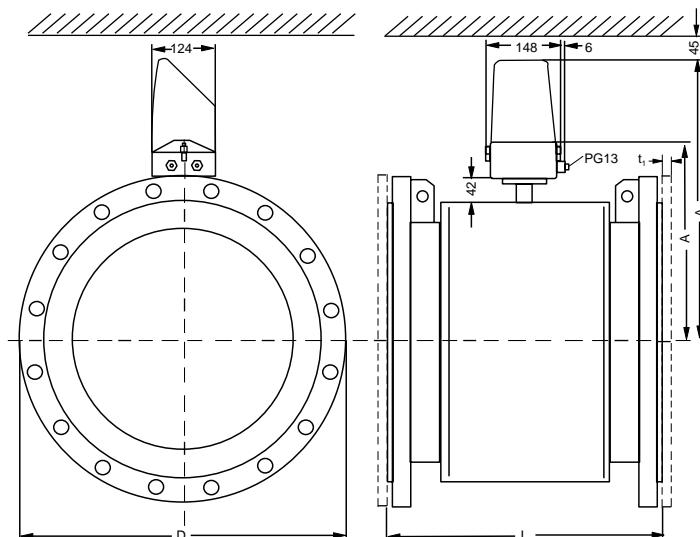

# Dimensions and Weights

DN mm	DIN 2501				ANSI				without MAG 6000/5000	with MAG 6000/5000	weight *) (kg)
	PN 16		PN 40		150 lb		300 lb		A	A1	
	L **)	D	L **)	D	L **)	D	L **)	D	(mm)	(mm)	
25			200	115	200	108	200	124	162	319	6
40			200	150	200	127	200	155	172	329	8
50			200	165	200	152	200	165	172	329	13
65	200	185	200	185	200	178	272	191	180	337	14
80	200	200	272	200	272	191	272	210	185	342	15
100	250	220	250	235	280	229	310	254	203	360	20
125	250	250	250	270	300	254	335	279	223	380	25
150	300	285	300	300	325	279	370	318	238	395	30
200	350	340	350	375	350	343	410	381	263	420	50
250	450	405	450	450	450	406	500	445	297	454	70
300	500	460	500	515	500	483	550	521	314	471	80
350	550	520	550	580	550	533	590	584	334	491	110
400	600	580	600	660	550	597	590	648	358	515	125
450	600	640	600	685	600	635	640	711	389	546	175
500	625	715	680	755	680	699	730	775	414	571	200
600	750	840	750	890	820	813	860	914	464	621	300
700	875	910							561	718	350
800	1000	1025							612	769	475
900	1125	1125							662	819	560
1000	1250	1255							713	870	700
1200	1500	1485							814	971	1250

All flange dimensions to DIN 2501 or ANSI B 16.5

\*) With signal converter MAG 6000/5000 mounted: Weight increases by 2 kg.

\*\*) If earthing flanges are used additionally, the thickness of the earthing flange and gasket must be added to the length.

## Available Sensor Designs

### Sensor MAG 3100W

Description	DN	PN
<b>Sensor Meimag 3100W</b> - Liner: Neoprene or EPDM (with KTW-approval) - Electrodes: AISI 316 Ti (stainless steel) - Flanges: ST 35, DIN 2501 - Accuracy: ±0,5 % - Pressure rate: see table - Temperature: 0 ... 70 °C - Protection class: - Integrated earthing electrodes (no additional earthing flanges necessary)  Other pressure rating, flanges and electrodes on request	25	40
	40	40
	50	40
	65	16
	80	16
	100	16
	125	16
	150	16
	200	10
	250	10
	IP 67 300	10
	350	10
	400	10
	450	10
	500	10
600	10	
700	10	
800	10	
900	10	
1000	10	
1200	10	

### Accessories MAG 3100W

Description
Submersible kit (IP 68 10 mWg 10 years) For use with standard MAG 3100 , when sensor is buried or permanently submersed
Earthing/Protection flange Typ C for all liners (only necessary for additional inlet protection for abrasive media)

## Available Converter Designs

### Converter MAG 5000

Description	Application	Protection
Converter MAG 5000 compact application (wall mounting with wall mounting kit see accessories)	115/230 V AC 50/60 Hz	IP 67, glass fibre reinforced polyamide
		IP 00, 19"-insert
	24 V DC (11 ... 30 V)	IP 67, glass fibre reinforced polyamide
		IP 00, 19"-insert
Converter MAG 6000 compact application (wall mounting with wall mounting kit see accessories)	115/230 V AC 50/60 Hz	IP 67, glass fibre reinforced polyamide
		IP 00, 19"-insert
	24 V DC (11 ... 30 V)	IP 67, glass fibre reinforced polyamide
		IP 00, 19"-insert
Converter MAG 6000 CT Pattern approved version	115/230 V AC 50/60 Hz	IP 67, glass fibre reinforced polyamide

### Accessories MAG 5000 MAG 6000

Other accessories on request

Description	
Wall mounting kit for IP 67 version wall bracket, 5 off Pg 13 screwed cable entries,	
Standard electrode and coil cable 3 x 1,5 mm² PVC	10 m 20 m 40 m 60 m 100 m
Special electrode and coil cable double screened PVC	20 m 40 m 60 m 100 m

L B 5600 INT / 001-0204 • Subject to change without notice